

A simple and elegant sofa, whose tapered back creates the effect of being suspended. This minimal, sinuous line, ideally suited to a contract setting, is an authentic declaration of style and design but, more than anything else, is an example of Cassina's outstanding prowess in the production of sofas. Aspen is available in two lengths, with the back-rest sloping either left or right, and can be personalised with removable leather or fabric covers.

### Gallery

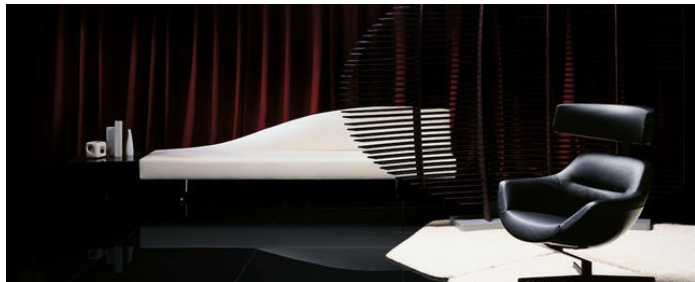

### Dimensions

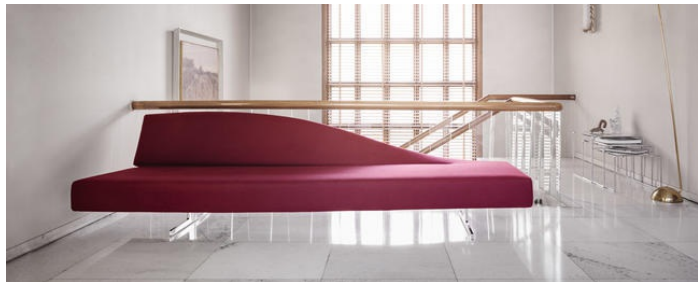
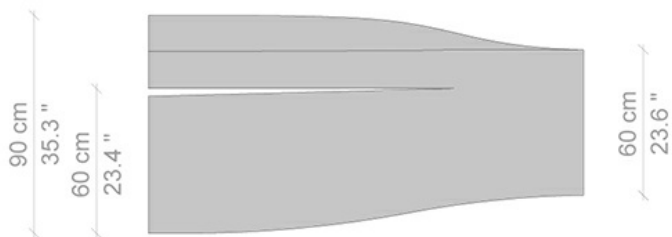
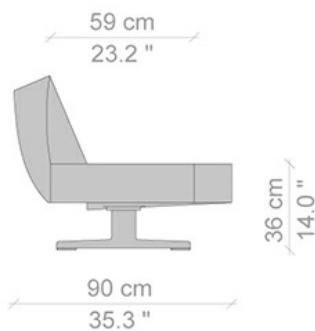
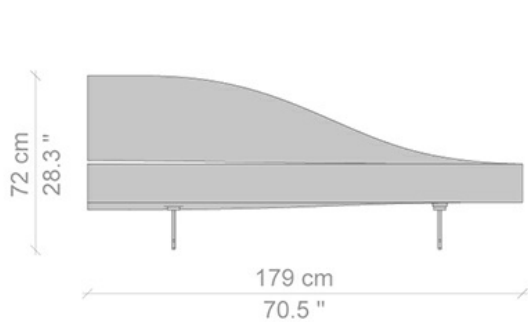

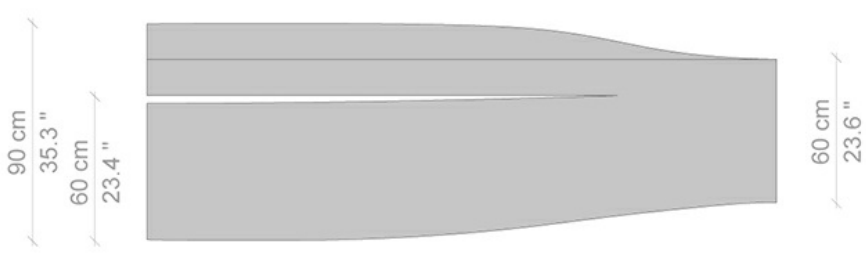
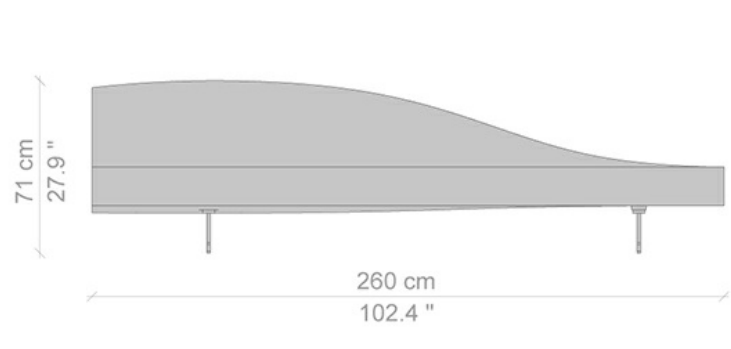
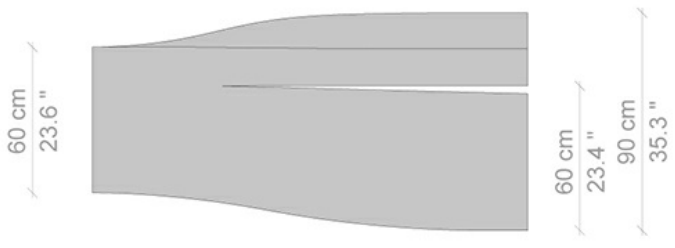
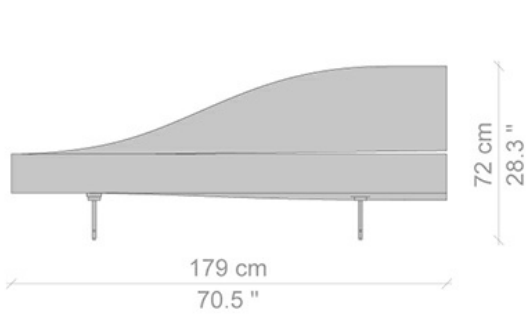

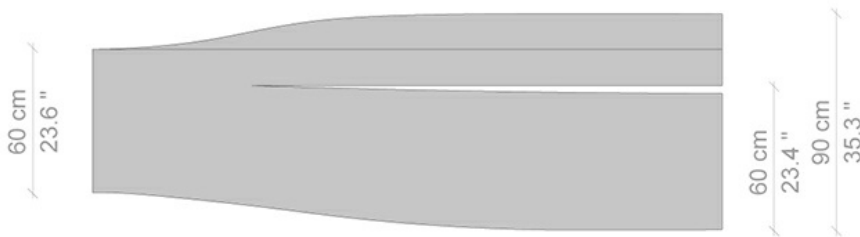
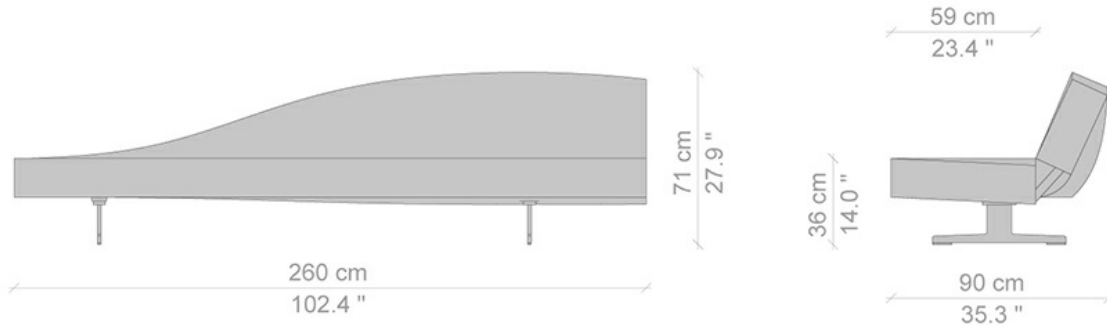

## Designer



**Jean-Marie Massaud**

Born in Toulouse in 1966, Jean-Marie Massaud graduated in 1990 from Les Ateliers, Ecole Nationale Supérieure de Création Industrielle, Paris. He began to work both in Asia and in France, finally opening his own office in Paris in 1994. Since then, he has dedicated himself to industrial and furniture design, building important relationships with brands such as Authentics, Baccarat and Magis. His collaboration with Marc Berthier and his work in the field of town planning led him towards design and architecture. He is concerned with design in various contexts, industrial products and furniture. His contextual approach centres on research into the essential, within which the individual remains the centre of attention. It is a work upheld by research into the senses, magic, and vital emotion which brings him to work with very different brands: Cassina, Poltrona Frau, Cappellini, Cacharel, Lancôme, Tronconi and Yamaha offshore. His works have been awarded several prizes and many of his designs are nowadays on show in the design collections of the major museums worldwide: from Amsterdam, Chicago, London, Paris and Zurich: from the permanent collection of the Musée National d'Art Moderne de Paris to the permanent collections of the Museum für Gestaltung, Zürich, of The Chicago Athenaeum- Museum of Architecture and Design, of The Stedelijk Museum, Amsterdam and of The Musée des arts Décoratifs, Paris.