Dike

BEDS

Antonio Citterio



Description

The new Maxalto Dike bed stands out for its unusually-sized headboard which is a distinctive element that creates a new furniture category. Antonio Citterio imagined two panels each 2 meters high and 125 cm wide, ending with two mobile elements, anchored by an elegant full-height hinge. This headboard becomes a theatrical backdrop or a structural element which is made even more sophisticated by the upholstery. Dike uses an ad-hoc designed fabric, with an enhanced three-dimensional and visible texture similar to a woven horizontal band tapestry making light and colour visual effects which fade gently into each other. The bed's height is significant and follows a precise concept for the bedroom. The bed and headboard structure can be covered with fabrics from the collection. This is a new and luxurious and refined range, hyperbolic but extremely calibrated, soft, and rational, which underlines Maxalto's renewed desire for excellence and originality.

Technical information

Internal frame

tubular steel and steel profiles

Internal frame upholstery

Bayfit® flexible cold shaped polyurethane foam, polyester fibre cover

Feet

tubular steel and steel profiles

Wheels support frame

steel

Wheels

plastic material

Ferrules

thermoplastic material

Internal frame (TDA380)

multi-layered wood panel

Wall fixing brackets (TDA380)

steel profiles

Hinge (TDA380)

steel

Cover

fabric

Technical drawings

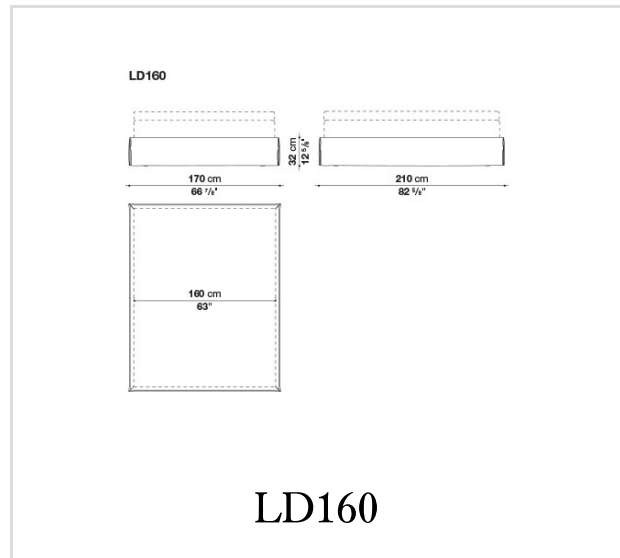
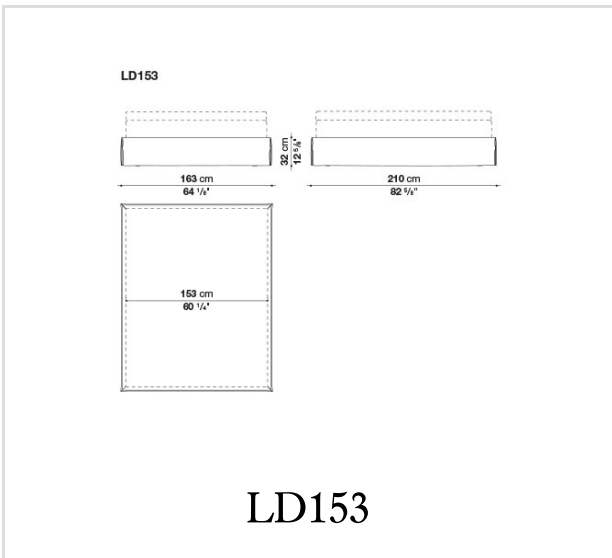
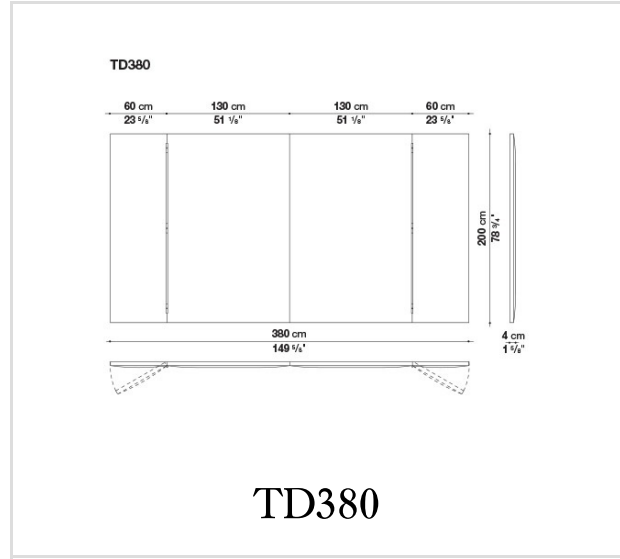
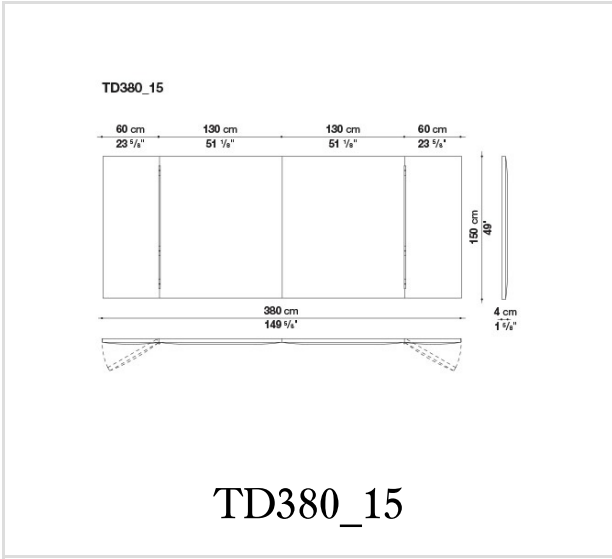

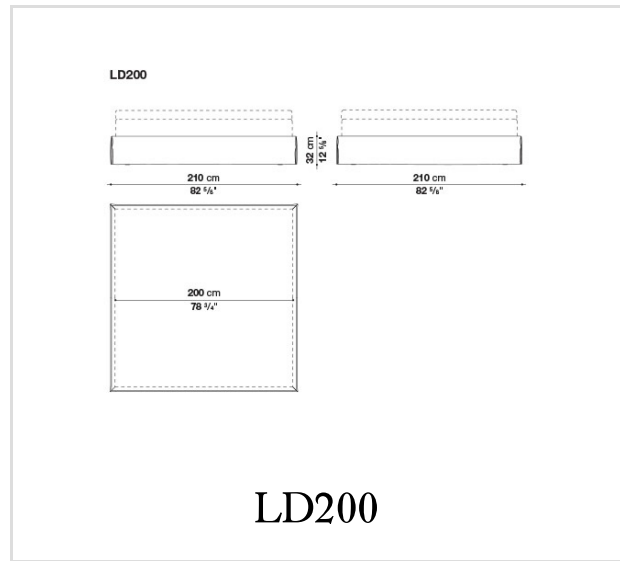
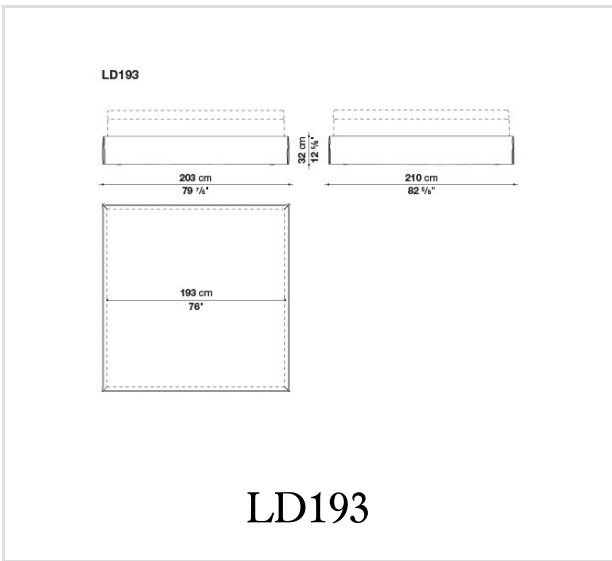
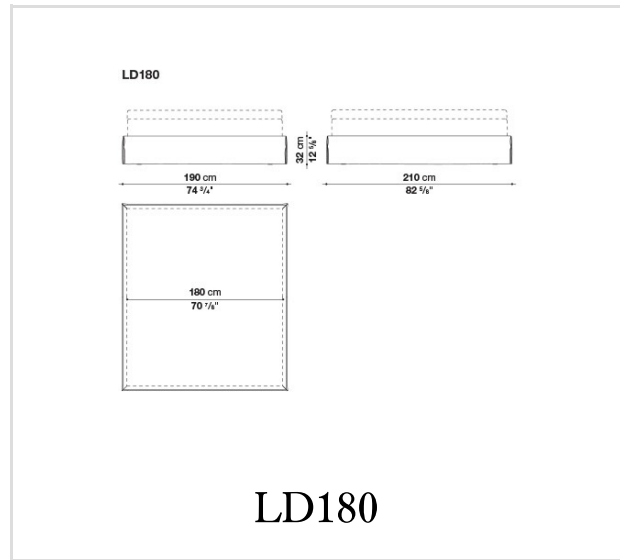
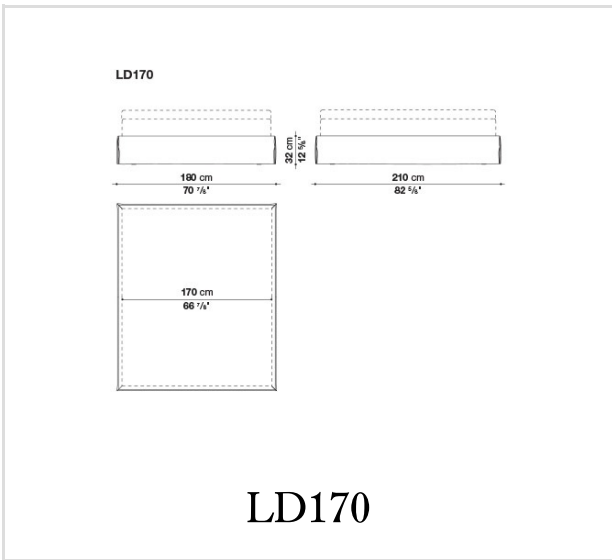

B&B Italia reserves the right to make technological and aesthetic improvements to its models, including changes to the sizes and materials, without notice. The technical drawings do not define the details of the product. The measurements shown are indicative and may undergo changes. In particular, the dimensions relevant to the padded parts are subject to usage tolerances over time caused by the normal adjustment of the padding. For the specific information, please contact the dealer closest to you.