

# Aluzen

IT

*AluZen* sorprende per la sua pulizia formale e la tecnicità in linea con il DNA di Alias; un'identità non legata alla tipologia ma alla coerenza progettuale. Alias seleziona per gli elementi imbottiti diversi rivestimenti, in pelle e tessuto, che proposti "tono su tono" o "mix and match" esaltano la purezza del design.

DE

*AluZen* wurde entwickelt für Zuhause und Hotelbetrieb und überrascht durch seine formale Reinheit und die für Alias typische Technik. Eine Identität, die nicht mit der Kategorie, sondern mit der Planungskohärenz in Verbindung steht. Alias wählt für die Polster Elemente unterschiedliche Bezüge aus Leder und Stoff aus, die "Ton in Ton" oder als "Mix und Match" die Reinheit des Designs hervorheben.

EN

*AluZen* stands out for its amazing formal purity and technological content, in perfect synchrony with the Alias DNA: an identity which, rather than deriving from the product type, is linked to the design consistency. Alias has selected various leather and fabric upholstery solutions for the sofa elements, which enhance the purity of this design with "tone on tone" or "mix and match" effects.

FR

*AluZen* surprend par sa sobriété formelle et sa technicité, en harmonie avec l'ADN d'Alias: une identité moins liée à la typologie qu'à la cohérence conceptuelle. Pour les éléments rembourrés, Alias a sélectionné différents habillages en cuir ou tissu, "ton sur ton" ou "mix and match", qui mettent en valeur la pureté essentielle du design.



ALUZEN  
*Ludovica e Roberto Palomba*

GRAN KOBI ESSENTIEL  
*Patrick Norguet*

MOBILE ZERO  
*Ron Gilad*

BIPLANE  
*Alberto Meda*





# Aluzen

**Ludovica & Roberto Palomba**  
**A snug furnishing solution designed for thinking, reflecting and meditating. An authentic project signed by Ludovica + Roberto Palomba design firm for Alias, which puts people at the centre of its research and becomes a proper island on which to enjoy moments of relaxation.**

Un sistema accogliente per pensare, riflettere, meditare. Un progetto autentico, firmato da Ludovica + Roberto Palomba per Alias, che pone al suo centro l'uomo, divenendo una vera e propria isola dove trascorrere i momenti di relax.

Ein gemütliches System zum Nachdenken und Reflektieren. Ein authentisches Projekt von Ludovica + Roberto Palomba für Alias, in dessen Mitte der Mensch steht. Eine Insel für Momente der Entspannung.

Un système accueillant pour penser, réfléchir ou méditer. Un projet authentique, signé pour Alias par le cabinet de design Ludovica + Roberto Palomba, qui place l'homme au centre d'une véritable île, idéale pour s'offrir des instants de détente.



# ALUZEN

aluzen ending dx + sx



aluzen ending dx + aluzen modul + aluzen low table



aluzen ending dx + aluzen angular sx



aluzen bench + aluzen low table



aluzen pouf



*Il segno elegante e sofisticato di Ludovica + Roberto Palomba si riflette in un'estetica leggera che caratterizza l'intero programma. La gamba, snella e rastremata, è realizzata in fusione di alluminio e, senza soluzione di continuità, diventa il telaio dell'imbottito. Una geometria portata al limite, sulla quale si agganciano le cinghie elastiche intrecciate che accolgono i morbidi cuscini geometrici.*

*The elegant and sophisticated design trait of Ludovica + Roberto Palomba is reflected in the light and airy aesthetic running through the entire project. Slim and tapered, the leg is made of die-cast aluminium and continues, uninterrupted, to form the frame of the upholstered element. An uncompromising geometrical element, which secures the interwoven elastic webbing supporting the soft geometrically shaped cushions.*

*Der elegante Stil von Ludovica + Roberto Palomba spiegelt sich wieder in einer leichten Ästhetik, die das gesamte Programm auszeichnet. Ein schlankes, verjüngtes Bein aus Aluminiumguss, das unterbrechungsfrei zum Rahmen des Polstermöbels wird. Eine bis ans Limit getriebene Geometrie mit elastischen, geflochtenen Riemen, auf denen die weichen, geometrischen Kissen liegen.*

*Les lignes élégantes et sophistiquées de Ludovica + Roberto Palomba se traduisent par une esthétique légère, trait distinctif de l'ensemble de la collection. Le pied mince et rétréci est réalisé d'aluminium. Sans solution de continuité, ils se prolongent dans le cadre de la structure rembourrée. Une géométrie tendue à l'extrême, à laquelle s'accrochent les sangles élastiques tressées qui accueillent des coussins géométriques, très souples.*

*AluZen prevede diversi elementi (angolari, chaise longue, pouf) che combinati tra loro consentono di creare infinite configurazioni. Una serie di accessori sospesi, che si raccordano alla struttura del divano, diventano preziosi dettagli che aumentano il grado di personalizzazione della composizione. A supporto del sistema, i pratici coffee tables con piano in marmo o laminato, caratterizzati dalla stessa struttura dell'imbottito.*

*AluZen comprises various elements (corner, chaise longue, pouf) which, when combined, allow an infinite number of different configurations. A series of suspended accessories, interconnected with the structure of the sofa, are the precious details enabling a greater customisation of the composition. Coordinated with the system, there is a range of practical coffee tables with marble or laminate tops, characterized by the same structure as the sofa.*

*AluZen bietet unterschiedliche Elemente (Ecksofa, Chaiselongue, Sitzpuff), die miteinander kombiniert werden können und unendliche Konfigurationen möglich machen. Eine Reihe von hängenden, am Sofa befestigten Accessoires werden zu wertvollen Details für die weiterführende Personalisierung der Komposition. Als Begleitung die praktischen Coffee Tables mit Marmor- oder Laminatplatte und der gleichen Struktur des Polstersofas.*

*AluZen comporte différents éléments (angulaires, chaises longue, pouf) qui, assemblés entre eux, permettent d'obtenir un nombre infini de configurations. Une gamme d'accessoires suspendus, raccordés à la structure du canapé, deviennent des détails précieux qui maximisent les possibilités de personnalisation de la composition. Le système est complété par des tables à café très pratiques, avec le plateau en marbre ou laminé, qui reprennent la même structure que celle de l'élément rembourré.*

ALUZEN

ALUZEN SOFA 3 + ALUZEN BENCH + TAVOLO ZERO + FLOW BOWL VASES



ALUZEN

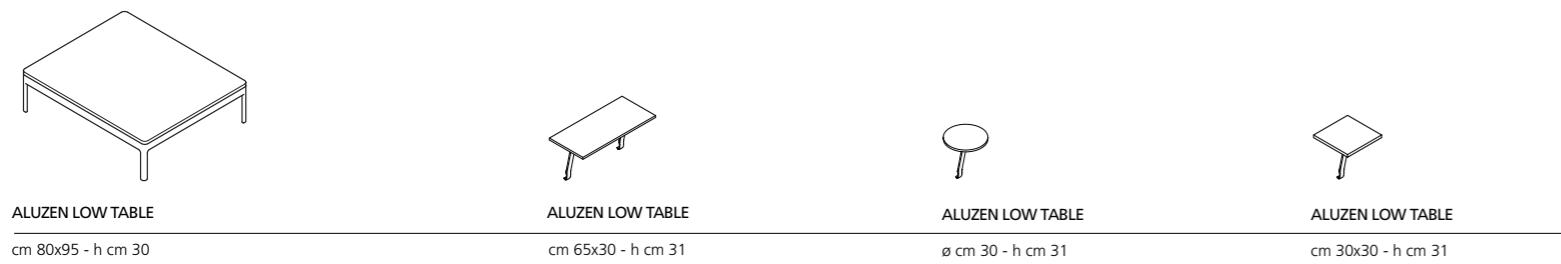
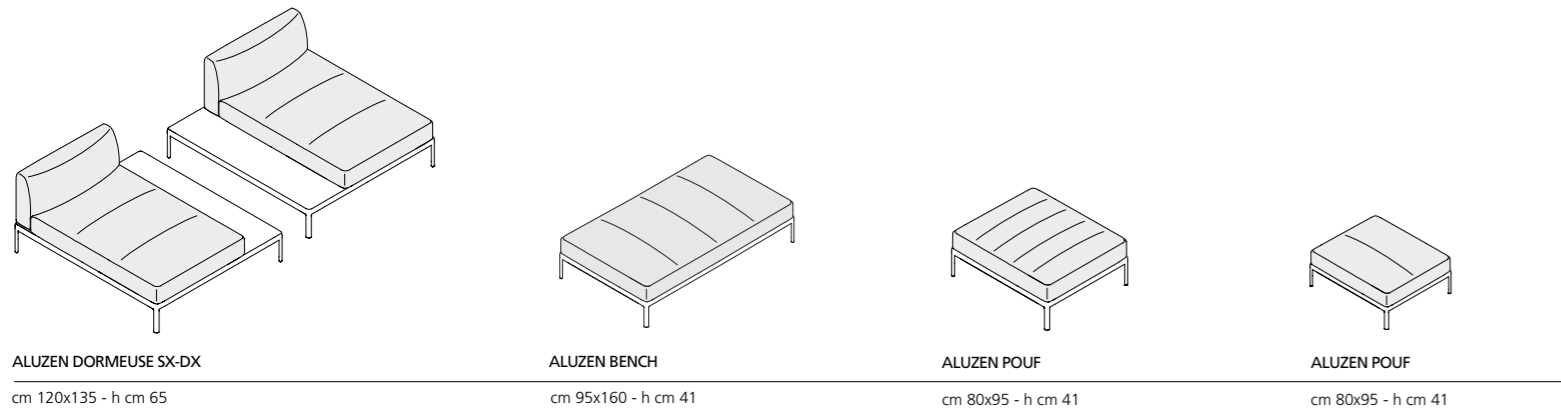
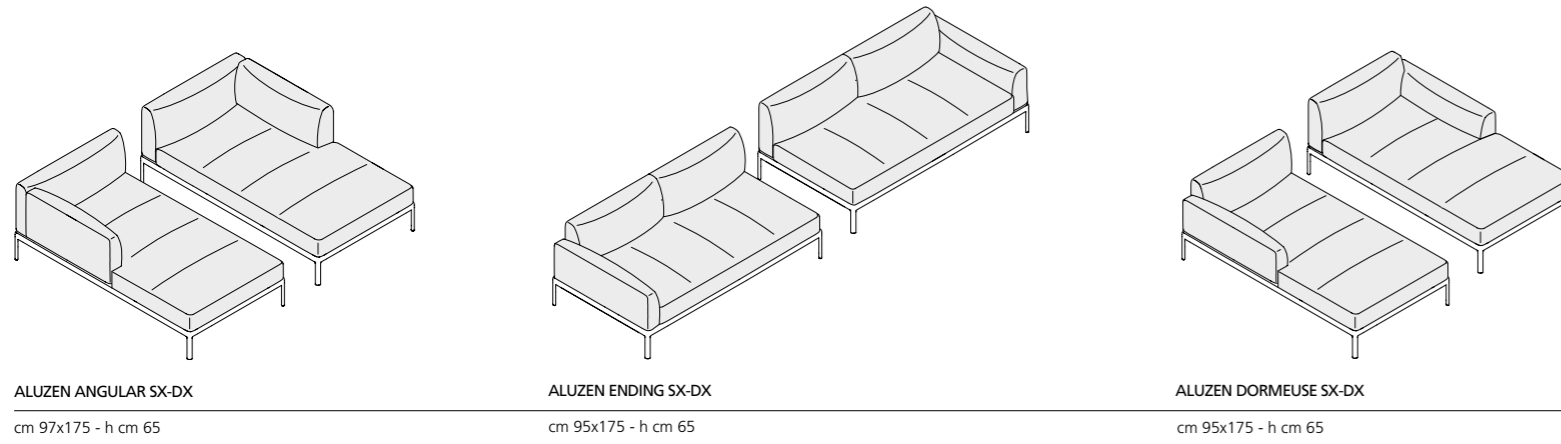
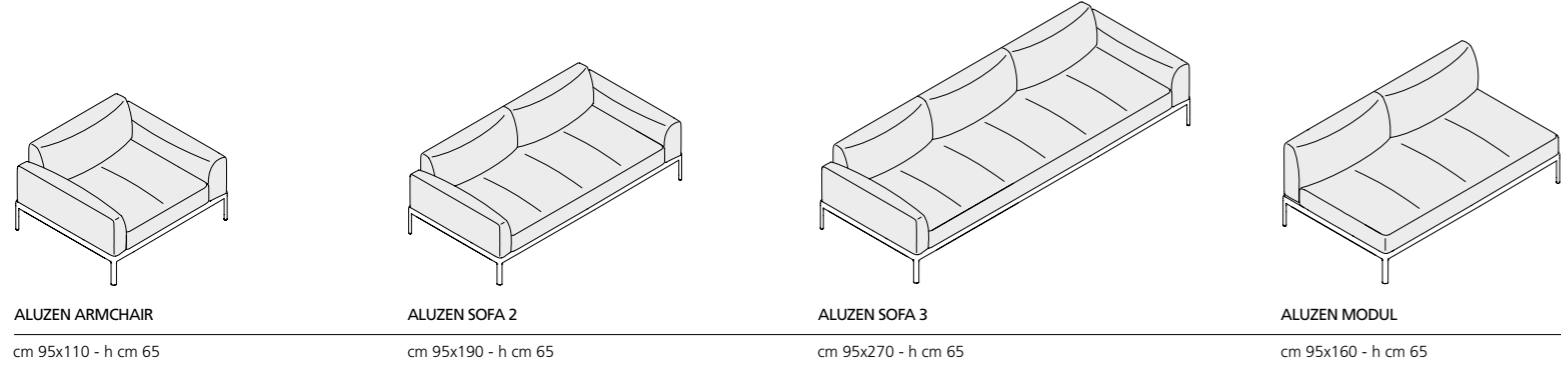

ALUZEN

## finiture / finishes / Ausführungen / finitions

struttura / structure / Gestell / structure

alluminio lucidato  
polished aluminium  
Aluminium poliert  
aluminium poli



AB

alluminio verniciato  
stove enamelled aluminium  
Aluminium lackiert  
aluminium laqué



A011

A019

A022

A047

seduta-cuscino / seat-pad / Wände-Kissen / assise-coussin\*

Tessuto A /  
Fabric A /  
Stoff A /  
Tissu A /

Camira®  
URBAN  
XTREME  
Alias® Living

Tessuto B /  
Fabric B /  
Stoff B /  
Tissu B /

Kvadrat®  
DIVINA  
MAPLE  
REMIX  
TONUS  
UMAMI  
UMAMI 2  
UMAMI 3

Tessuto C /  
Fabric C /  
Stoff C /  
Tissu C /

Kvadrat®  
CANVAS  
DIVINA MELANGE  
FOSS  
HALLINGDAL 65  
HARALD  
HERO  
STEELCUT  
STEELCUT TRIO  
TWILL WEAVE

Eco pelle A /  
Synthetic leather A /  
Kunstleder A /  
Simil cuir A /

Serge Ferrari®  
Stamskin® Top

Pelle /  
Leather /  
Leder /  
Cuir /

Pelle Frau®

Pelle Penelope Oggi® /  
leather Penelope Oggi® /  
Leder Penelope Oggi® /  
cuir Penelope Oggi® /



LA01

LA02

LA03

LA05

LA06

LA07

LA11

piano Table / top Table / Tischplatte Table / plateau Table

MDF laccato  
stove enamelled MDF  
MDF lackiert  
MDF laqué



V001

V003

V007

V130

marmo di Carrara  
Carrara marble  
Carrara-Marmor  
marbre de Carrara



MA01