

Lens

TABLES

Patricia Urquiola

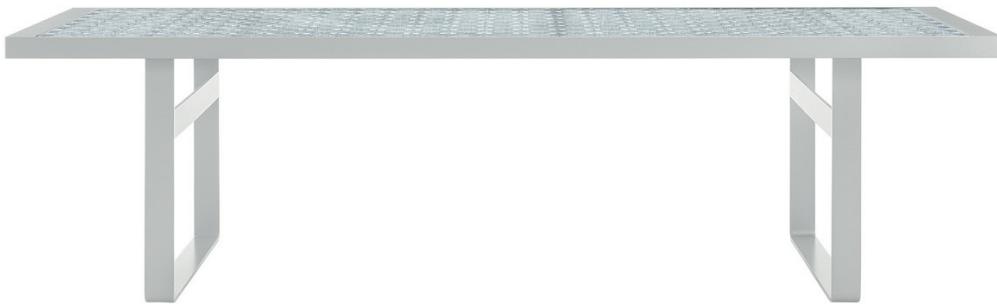

Description

The result of the study of transparent surfaces that are rich in special effects, it is inspired by the kaleidoscope, by the glass panes of 18th century Venetian palaces, and produces optical effects: the top of the table Lens was obtained through the coupling of two glass sheets with a special internal film to enhance surface depth. The elegant supporting frame is made of white painted metal.

Technical information

Top:
satin glass and lenticular film

Frame:
painted drawn steel

Finish:
chalk white painted steel with satin glass

Technical drawings

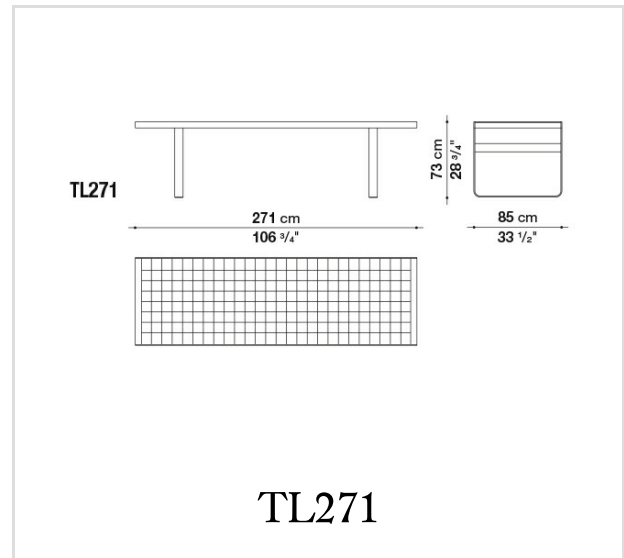
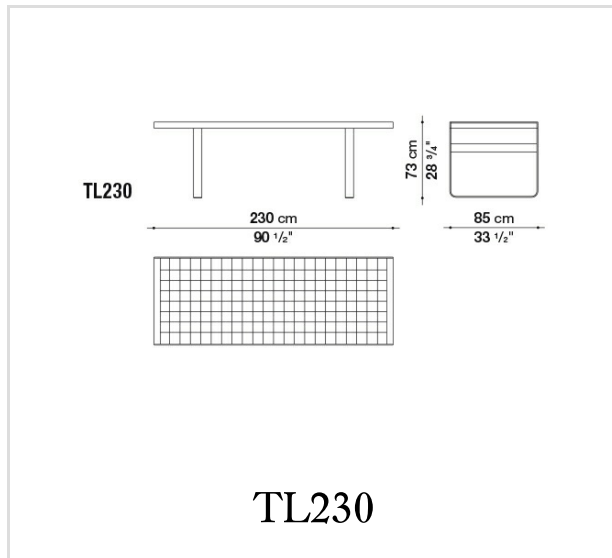

B&B Italia reserves the right to make technological and aesthetic improvements to its models, including changes to the sizes and materials, without notice. The technical drawings do not define the details of the product. The measurements shown are indicative and may undergo changes. In particular, the dimensions relevant to the padded parts are subject to usage tolerances over time caused by the normal adjustment of the padding. For the specific information, please contact the dealer closest to you.